

REV.	MODIFICATION.	DATE	DRN
04	CO2010058	18/02/08	SF
05	CO2010064	19/02/08	SF

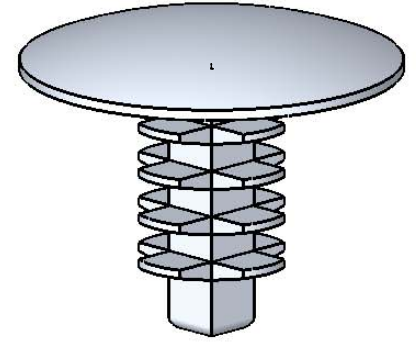

TO PRESS FIT IN A
 $\phi 3.50 \pm 0.05$ [0.14 \pm 0.002] HOLE
 IN A 6.35 [0.25] MIN. THICK
 PANEL

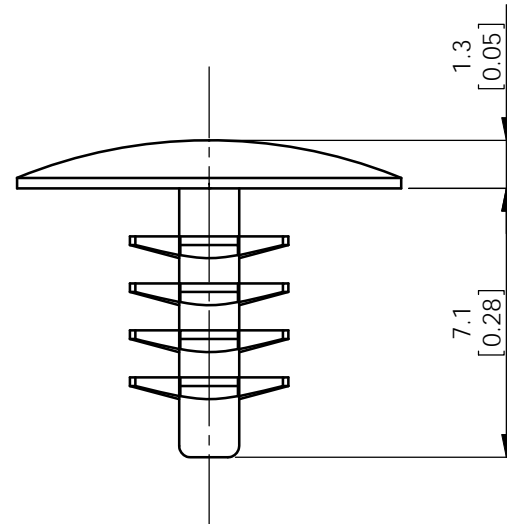
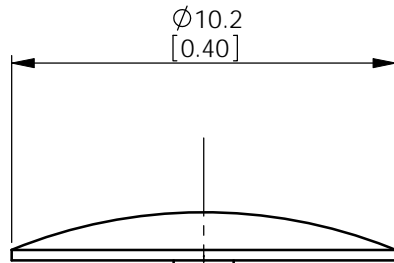
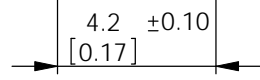

INFORMATION CONTAINED IN THIS DOCUMENT IS CONFIDENTIAL TO RICHCO INTERNATIONAL Co. Ltd. AND MAY NOT BE DISCLOSED OR REPRODUCED IN WHOLE OR PART WITHOUT THEIR WRITTEN CONSENT.

	ALL DIMENSIONS IN mm GENERAL TOLERANCES ± 0.25 UNLESS OTHERWISE STATED 1 DECIMAL PLACE ± 0.25 2 DECIMAL PLACES ± 0.10 ANGULAR $\pm 1^\circ$	THIRD ANGLE

MATERIAL: SEE TABLE	COLOUR: NATURAL
------------------------	--------------------

DESCRIPTION: PRESS FIT PIN	PART No: SEE TABLE
-------------------------------	-----------------------

DRG No: 375-0004	NPR No: N/A	Mass:(g) 0.9	SHEET SIZE A4
---------------------	----------------	-----------------	------------------

DRN SF	DATE 18/02/08	CHKD TC	DATE 18/02/08	SCALE NTS	SHEET No. 1 OF 1
-----------	------------------	------------	------------------	--------------	---------------------

PART NUMBER	MATERIAL
PFP-7-01	NYLON 6/6 UL 94 V2(RMS-01)
PFP-7-19	NYLON 6/6 UL 94 V0 (RMS-19)